

Myriad Design – A-B Selector V2 – Construction & User Guide

User guide V1 Nov 2017 – with firmware rev 1U

1. The package should include the following items. If any of the items are missing from the package, please contact sales@stompville.co.uk :

Designation	Description	Marking
R1	1/8W resistor 180k Ohm	brown-grey...
R2, R3, R5, R7	1/8W resistor 10k Ohm	brown-black...
R4, R6	1/8W resistor 470 Ohm	yellow-violet...
R8, R9	1/8W resistor 680 Ohm	blue-grey...
C1, C2	ceramic capacitor 100nF	100n or 104 (radial leads)
C3	electrolytic capacitor 10uF	25V or 50V rated
C4, C5	ceramic capacitor 10nF	10n or 103 (axial leads)
U1	voltage regulator 5V – LP2950-5	KY5050 or 2950CZ-50
U2	microcontroller ATtiny84A-PU	label with firmware revision marked
RL1, RL2	latching relay	TQ2-L-5V or EA2-5SNJ or FP2-D3043
-	DIL socket 14-pin	-
-	printed circuit board	6514V2

Note: Stomp switches, LED's and battery clip are not included in the kit. LED's should be approximately $V_f = 2V$, $I_f = 4mA$ unless you change the value(s) of R8, R9.

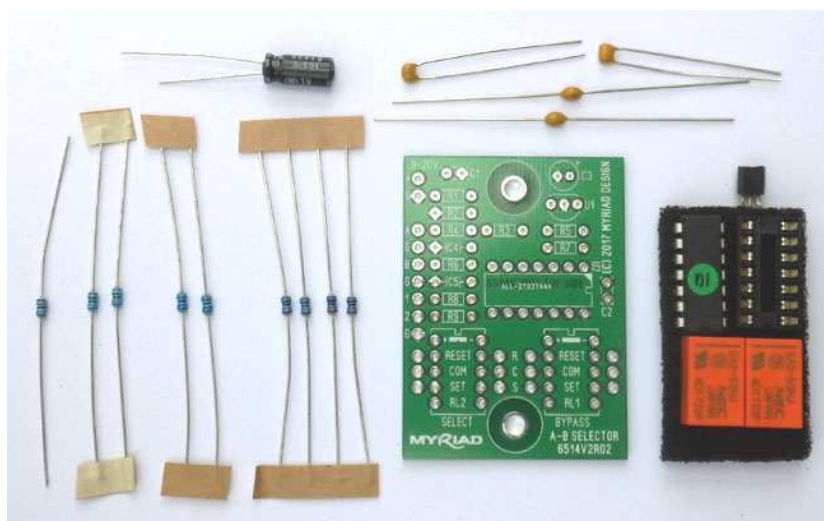

2. It is assumed that you have some experience of soldering and building of simple kits and are confident to build or modify effects pedals. If not, there are many informative tutorials and videos on the internet.

3. Note that U1 and U2 are electrostatic sensitive devices and should be handled with care. If you have an ESD protective wristband, use that. If not, wear clothes made of natural materials (e.g. cotton), regularly touch your finger to an earthed (grounded) metal object (such as a central heating radiator) and do not handle the sensitive devices any more than you have to. In particular, don't remove them from the electrostatic protective foam until you are ready to fit them to the board.

4. Solder the items to the PCB according to the silk-screen legend, checking and ensuring that you insert each component in the correct orientation (resistors and ceramic capacitors may be fitted either way). Electrolytic capacitor C3 must be fitted the correct way):

5. Connect the board as follows:

- Connect a 9V battery clip to the + and G terminals.
- Connect LED A between 1 and G (with cathode to G).
- Connect LED B between 2 and G (with cathode to G).
- Connect momentary-action switch A between A and G.
- Connect momentary-action switch B between B and G.

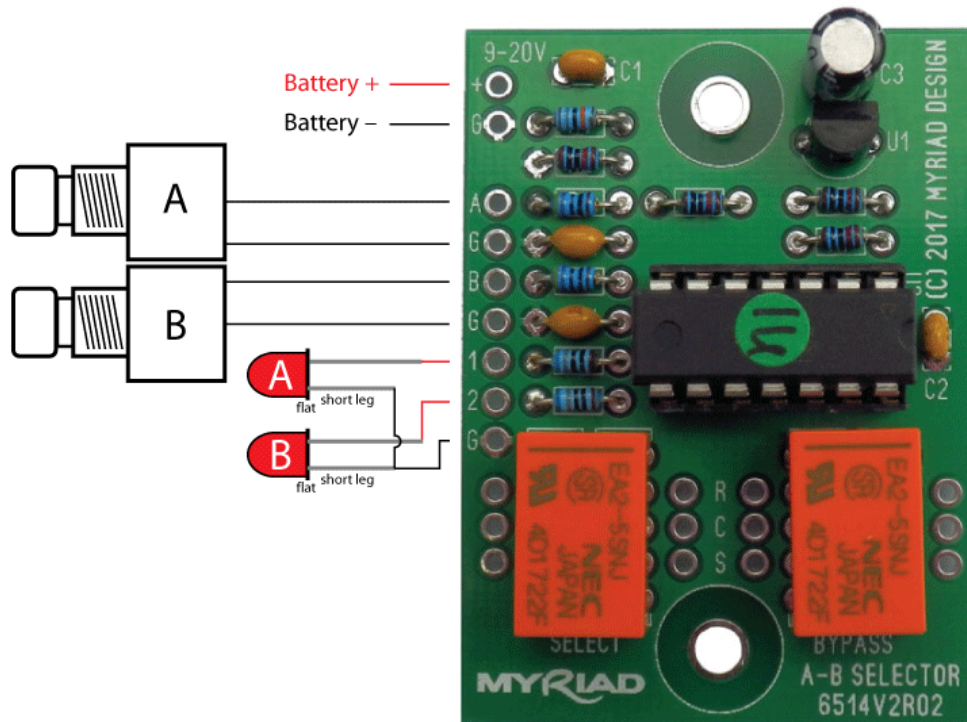

Note that if you choose to use a power supply instead of a 9V battery to test, be aware that there is no reverse voltage protection on the circuit board and if you connect a power supply the wrong way round, you may fry the voltage regulator. So, use a laboratory power supply with current limiting set to about 30mA.

6. At the end of factory-testing, the microcontroller (U2) should be set to bypass-on-power-up, but this may not be true in every case. We will assume it is true.

7. Connect a 9V battery to the battery clip. You should see the LED flash once and then go out. You may hear the relay click. The unit is in bypass (effect-off) mode.

8. Press and release the A switch. The bypass relay should click and LED A (1) should come on. Press and release again and the relay/LED should go off.

9. Press and release the B switch. The bypass relay should click and LED B (2) should come on. Press and release again and the relay/LED should go off.

10. Press the A and B switches in turn. You should see the device switch between A mode, B mode and bypass mode (both LED's off) in the expected way.

11. Disconnect the battery. Hold-down the A switch and re-connect the battery whilst holding the switch. This puts the unit into mode-A-at-power-up. Alternatively, if you hold down the B switch and power up, the unit will power up in B-mode. If you press both buttons and power up, the unit will revert to bypass-on-power-up.

12. If the LED's flash five times when you power up, this indicates that the battery voltage has fallen to about 7.3V (or less) and you should consider changing the battery soon. If you want to disable the low-battery function, omit R1 (but do still fit R2 or fit a shorting link in place of R2).

13. The maximum supply voltage is 20V d.c. Any voltage higher than this may damage the microcontroller (because the voltage at pin 3 will rise above 5V). If you omit R1 (and thereby lose low-battery indication), the maximum supply voltage rises to 30V d.c. Any voltage higher than this may damage the voltage regulator.

14. Now you have tested the unit, you can connect it to your effect board. There are various ways you could use this A-B Selector, but the following shows the basic design:

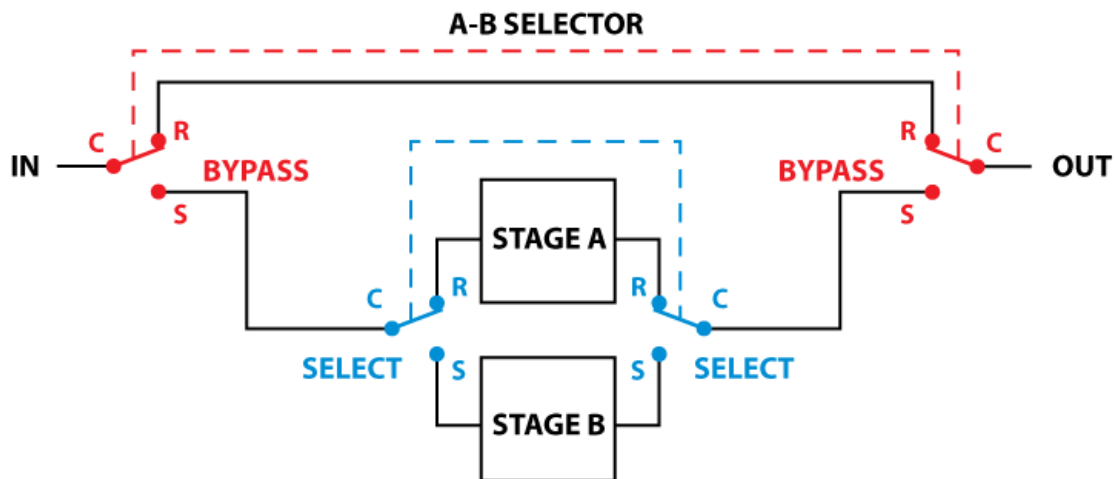

Because the relays are latching, they have SET and RESET instead of Normally Open (NO) and Normally Closed (NC). All twelve relay connections are available and they are marked R, C and S on the PCB silkscreen.

15. Troubleshooting. If the LED's do not light at all:

- Check the battery isn't dead.
- Check the battery is connected the right way round.
- Check the LED's are connected the right way round. (The cathode is the shorter leg and is adjacent to the flat on one side of the LED).
- Check the electrolytic capacitors are connected the right way round.
- Check the microcontroller is inserted the right way round.
- Check for any solder bridges on the under-side of the board.
- Check for any joints which have not been soldered.
- Check for dry joints.
- Check that there is 5V d.c. between pin 1 and pin 14 of the microcontroller.

16. If the LED's are too bright, you need to increase the value of R8/R9. Try 1k0, 1k2 or 1k5 (or keep going up to about 3k3). If the LED is too dim or you have a blue or white LED with a forward voltage of about 3.2V then you need to reduce the value of R3. For a white LED at about 5mA, R3 should be 330 Ohms. Don't go below about 150 Ohms.

17. If you have any questions or comments which may be relevant to others, please consider posting on the Stompville blog. Alternatively, you can email smudgerd@stompville.co.uk.

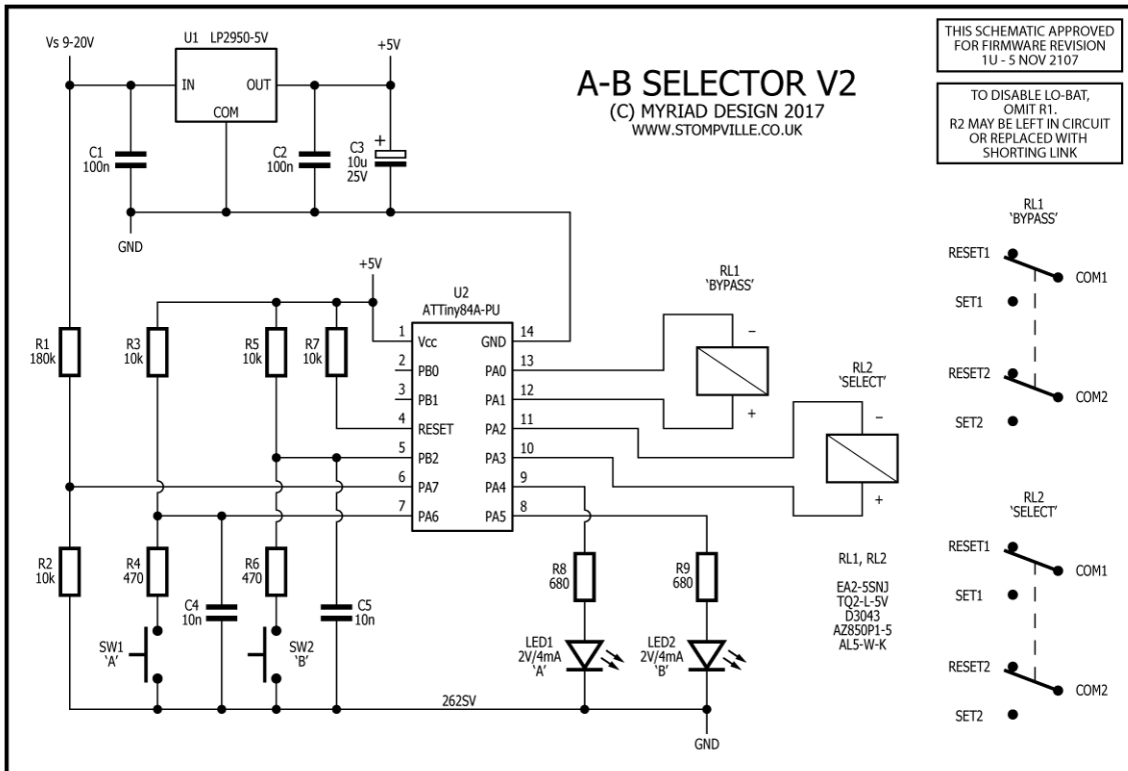

Note: Omit R1 to disable low-battery warning. If R1 is omitted, maximum supply voltage rises to 30V d.c.

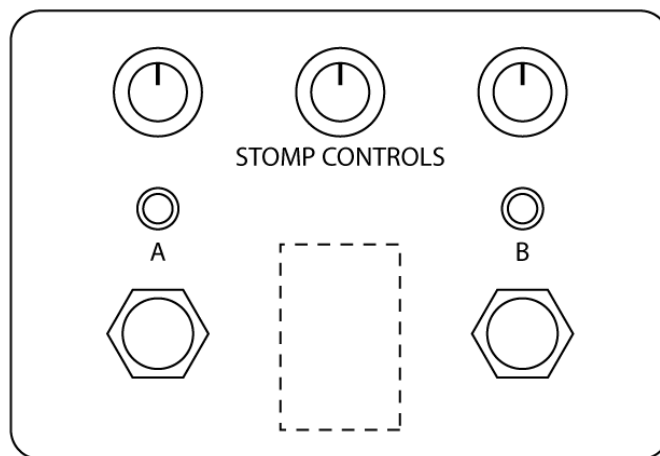

Suggested Mounting Arrangement

Copyright 2017 Myriad Design. All rights reserved.

Disclaimer.

The information contained herein is provided in good faith. Myriad Design has no control over the standard of construction of this kit, nor any control over the way the design is implemented or integrated into a third-party product. Therefore, Myriad Design offers no actual or implied warranty of fitness for purpose and Myriad Design will accept no liability for consequential loss or damage. This design is not authorised for use in any safety-critical system. Your statutory rights are not affected.

Myriad Design · United Kingdom
www.stompville.co.uk sales@stompville.co.uk